

# Sattelschrank 1060/1500 x 600 x 600 mm (HxBxT) Bausatz

ASSEMBLY INSTRUCTIONS SADDLE CABINET KIT

INSTRUCTIONS DE MONTAGE POUR KIT D'ARMOIRE DE SELLERIE

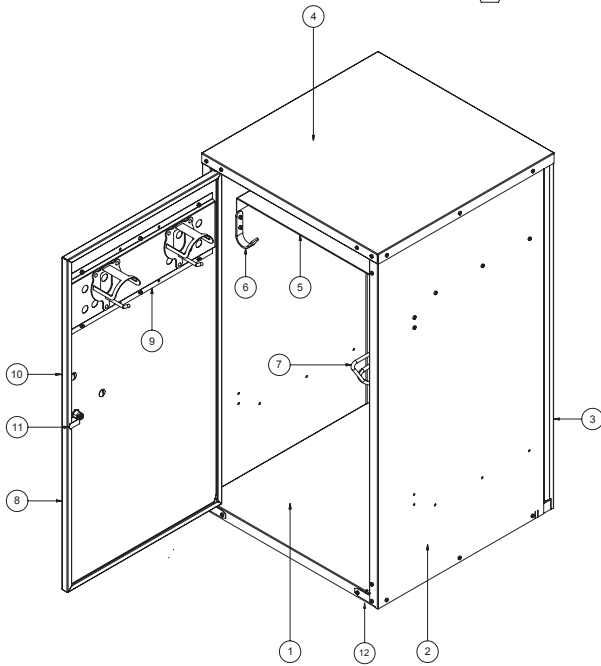
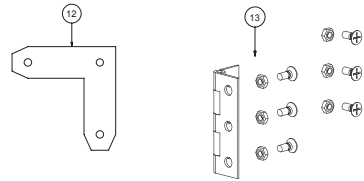
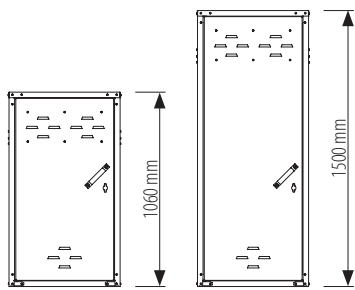

Pos.	Stck. / pc.	Bezeichnung / Description / Description
1	1	Bodenblech / Floor Panel / Tôle de Fond
2	2	Seitenwand Links + Rechts / Side Panel Left + Right / Paroi Laterale à Gauche + Droite
3	1	Rückwand / Back Panel / Paroi Arrière
4	1	Deckel / Cover Panel / Couverture
5	1	Einlegeboden / Shelf / Étagère
6	2	Trensenhaken / Bridle Holder / Support Bride
7	2	Sattelhalter / Saddle Holder / Support de Selle
8	1	Tür / Door / Porte
9	1	Trensenhalter / Bridle Holders / Supports Bride
10	1	Griff / Handle / Poignée
11	1	Schloss / Lock / Cerrure
12	4	Schraubwinkel / Angle for screwing / Angle à Viser
13	2	Scharnier / Hinge / Charnière
	12	Schraube M4x10 Din 965 / Screw M4x10 Din 965 / Vis M4x10 Din 965
	12	Mutter M4 Din 934 / Screw Nut M4 Din 934 / Écrou M4 Din 934
14	46	Schraube M5x10 / Screw M5x10 / Vis M5x10
15	46	Mutter M5 / Screw Nut M5 / Écrou M5
16	12	Mutter M10 für Sattelhalter / Screw Nut M10 for Saddle Holder / Écrou M10 pour Support Bride

Großewinkelmann  
www.growi.de



1. Verschrauben Sie die Rückwand mit dem Boden.  
Bolt the Back Panel together with the Floor Panel.  
Visez le Paroi Arrière avec le Sol.

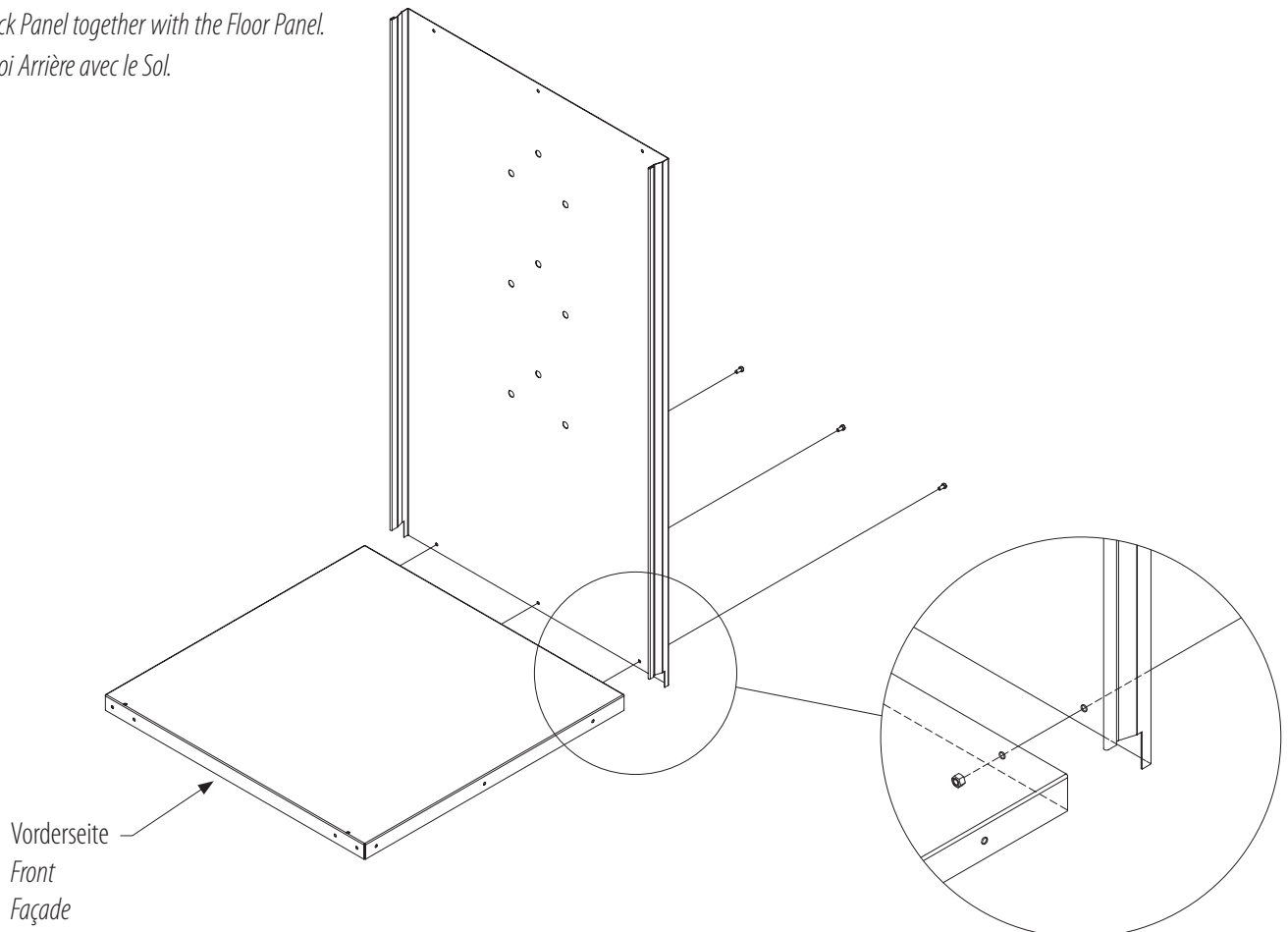





- 6.** Schrauben Sie die beiden Scharniere oben und unten an die Tür und in die Seitenwand und schrauben Sie das Blech mit den Trensenhaltern an die Innenseite der Tür.

*Screw the hinges on the top and the bottom of the door and into the side panel and fix the metal plate with the bridle holders on the inside of the door.*

*Vissez les charnières en haut et en bas de la porte et au paroi latéral et vissez le tôle métallique avec les supports de bride à l'intérieur de la porte.*

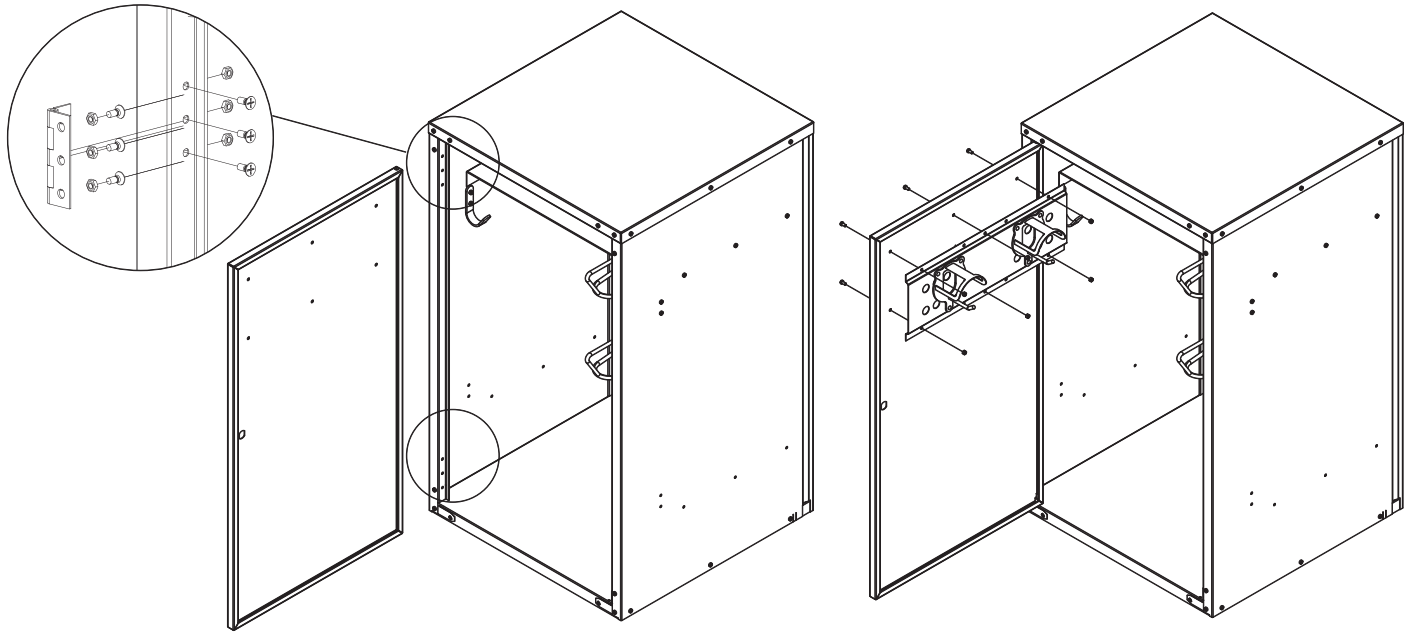

- 7.** Montieren Sie das Schloss.

*Install the lock.*

*Installez la Cerrure.*

